

INSTALLATION AND OPERATING INSTRUCTION

AUTOMATIC CHLORINE FEEDER

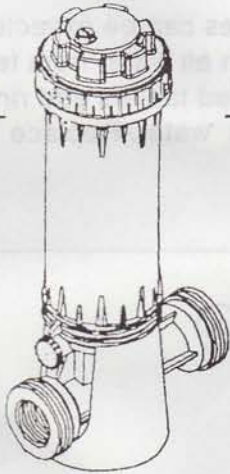

This automatic chlorine feeder is designed for installation in the return line to your pool or spa. It uses slow-dissolve Trichloro-S-Triazinetrione (Tri-Chlor) large or small tablets (or sticks) ONLY.

No other type of chemical should ever be used in your chlorine feeder. This CHLORINATOR holds up to 9 large (3" diameter) tablets or about 4.2lbs. of small tabs and has a dial type control valve to regulate the rate of water through the chlorine feeder. This capacity, under normal conditions, should provide a minimum of one week chlorination for large pods and up to two weeks for smaller pools. By regulating the valve setting between FULL (more chlorine) and 1/8 (less chlorine) and the amount of Tri-Chlor tablets you place in the feeder, you can easily adjust the chlorine feed rate that is necessary to maintain the proper chlorine residual for your pool.

INSTALLATION

1. This automatic chlorine feeder is for permanent installation in the pool water return line.
2. Always install the chlorine feeder after the heater. If there is no heater, install after the filter. Damage to the heater or filter may result if concentrated chlorine is allowed to flow through them.
3. This Chlorinator is furnished with 1 1/2" female threads. 1. Thread of socket adapters may also be used.
Use pipe thread sealants formulated and approved for use with plastic connections. Do not overtighten.
4. The preferred installation is above water level and located in line below filter or heater outlets. An In-line positive seal corrosion resistant check valve should be installed to reduce backflow of chlorine gas when the system is shut off. If the chlorine feeder must be located below water level, provide a check valve to prevent water backflow when opening/servicing the unit.

DIRECTIONS FOR USE

Before start up of your chlorine feeder, your pool/spa should be properly conditioned and have a chlorine residual of approximately 1.0 to 1.5 ppm. Follow dealer and chemical manufacturer's directions and instructions.

The chlorine demand for pools and spas varies based on use, temperature, sunlight, etc. Initially, you will have to experiment to determine the proper amount of chlorine and the correct valve setting required for your pool and filter time cycle. Using an 18,000 gallon pool as a guide, we suggest you place about 6 large, slow-dissolve Tri-Chlor tabs (or about 3lbs. of small slow-dissolve tabs or sticks) in your feeder and place the dial valve setting at 1/4. Reduce or increase the valve setting according to pool size, i.e. 30,000 gallons; set valve at 1/2.

Check chlorine residual daily and adjust the dial valve for more or less chlorine. Increasing the quantity of chlorine in your feeder will extend the time between recharging your feeder with more chlorine.

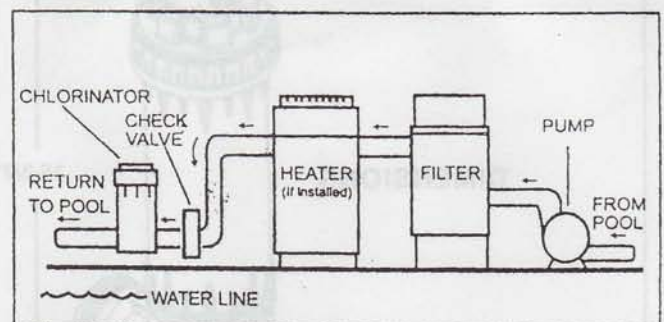

NOTE: Never install chlorine feeder directly into copper plumbing as pipe damage may occur. If you have brass or bronze backwash valves, or other sensitive metallic components, consult your dealer for precautions or recommendations for your particular system.

TO OPEN CHLORINE FEEDER:

1. Shut off pump and turn Dial Control Valve to OFF.
Shut off any other in-line valves to prevent back flow-if applicable.
Wait one minute.
2. Unscrew the plug with gasket on the top of the lid to release any accumulation of gas under the lid.
3. Turn knurled Cover Cap counter-clock wise to open. Caution: Do not inhale fumes from chlorinator.

TO CLOSE:

1. Place Cover, with O-ring seal, onto body, Engage Cover threads and turn clockwise to secure. Hand tighten only.
2. Place Dial Control Valve to desired setting. Open in-line valves and re-start pump.

INSTALLATION AND OPERATING INSTRUCTION

LUBRICATION

Never use petroleum type lubricants on Cover O-ring
To lubricate, use Ivory bar soap or Jack's No. 327
lube only.

WINTERIZING

Where freezing temperatures can be expected,
remove drain plug and drain all water from feeder.
Carefully remove undissolved tablets and rinse out
chlorinator thoroughly with water. Replace Cover
and engage 1 1/2 turns.

PARTS

REF. NO.	PART NUMBER	DESCRIPTION	NO. REQ'D.
1	●O67-03	Lid	1
2	●O67-04	O-Ring	1
3	●O67-05	Control Knob Assembly	1
4	●O67-06	Check Valve Assembly	1
5	●O67-07	Drain Plug-w/Gasket	1
6	●O67-08	Gaz Release plus w/gasket	1

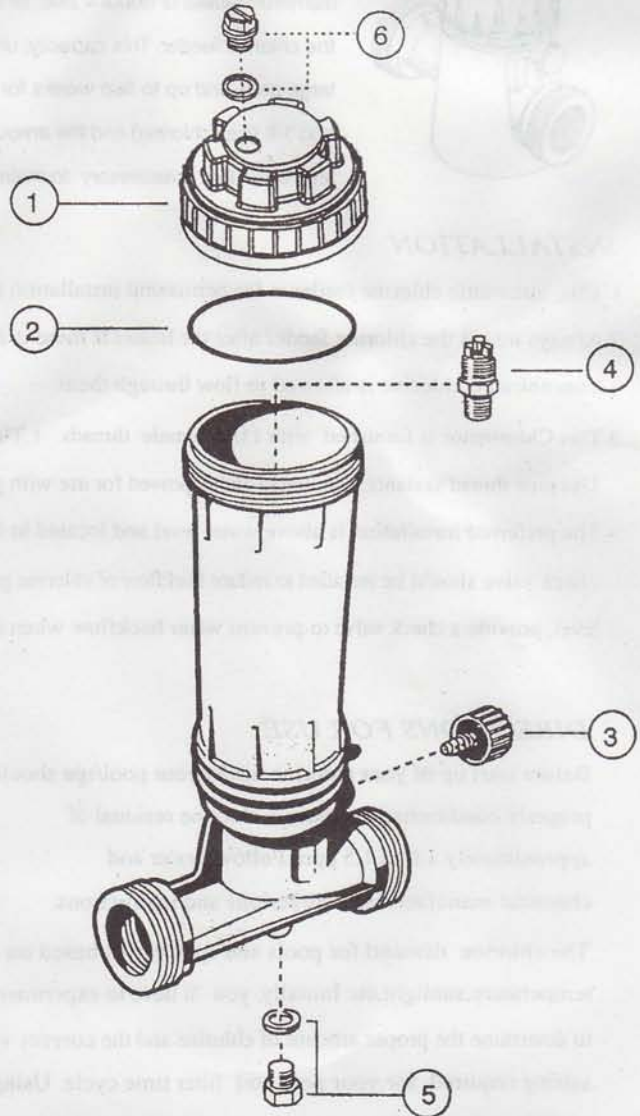

DIMENSIONS

